



Monitoring of cutting tools in TBM'S

Thomas Edelmann | Herrenknecht AG

Tunnelbauforschung in Leoben, Schwanau und Bochum

Workshop am 30.09.2013, Ruhr Universität Bochum)



CONTENT

- A. Introduction
- B. Cutting tools
- C. Monitoring
- D. Monitoring systems
- E. Inspection systems
- F. Cutting tool change
- G. Summary

A. INTRODUCTION

Monitoring of Softground and Hard rock tools / cutter heads is different

Softground TBM: EPB TBM / MIX SHIELD TBM

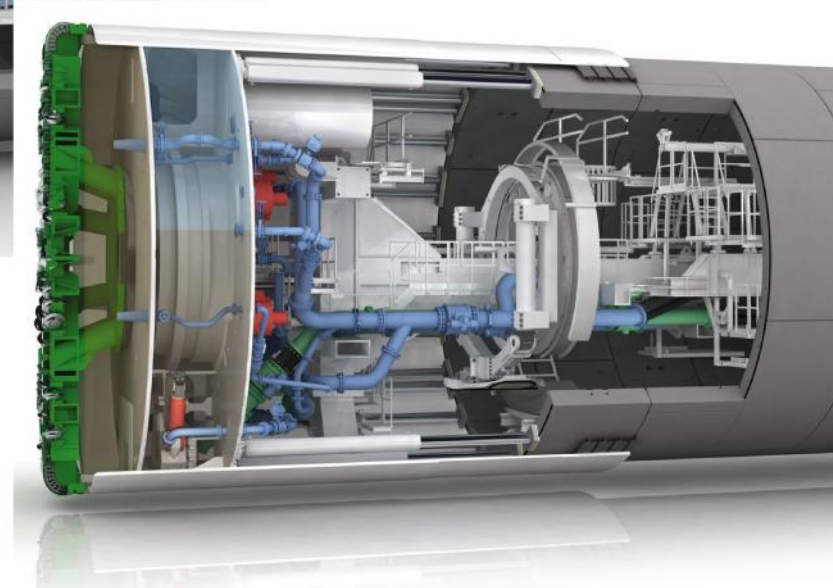
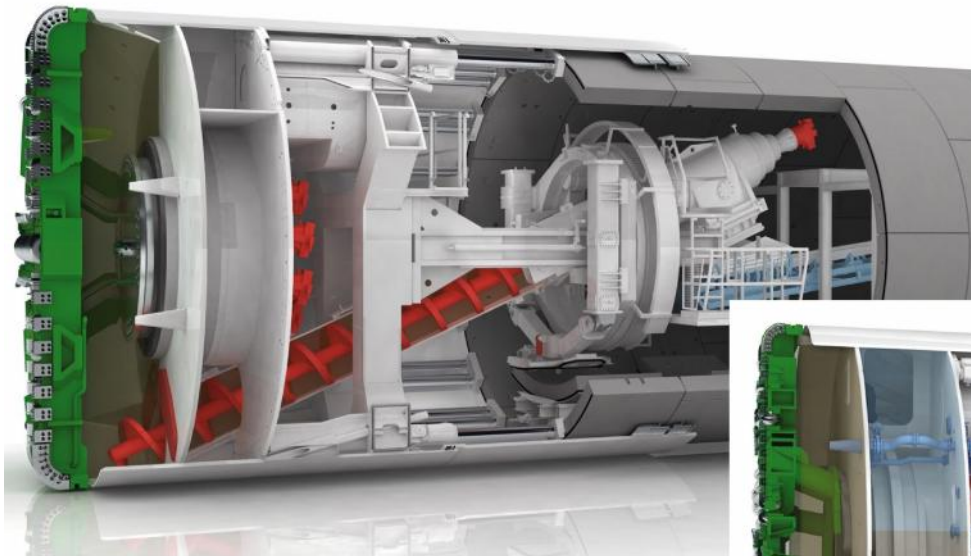

Softground:

- Wear
- Rotation

A. INTRODUCTION

HARD ROCK TBM:

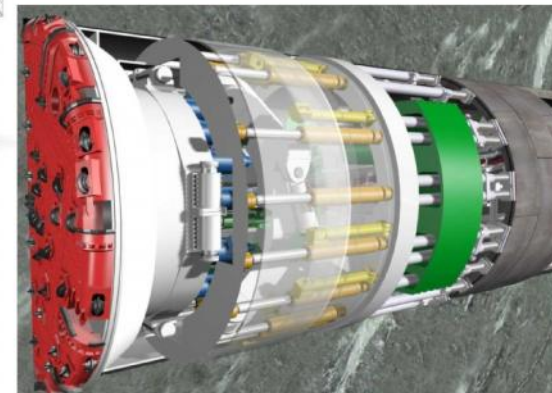
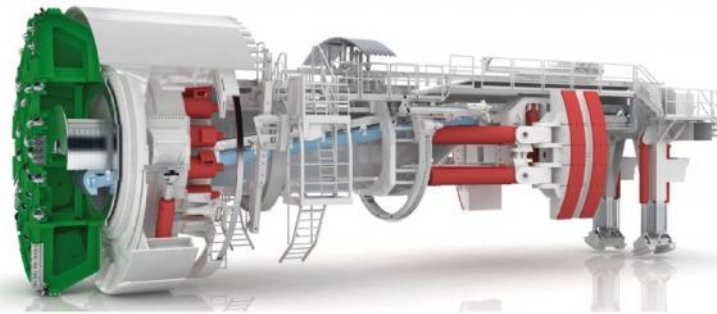
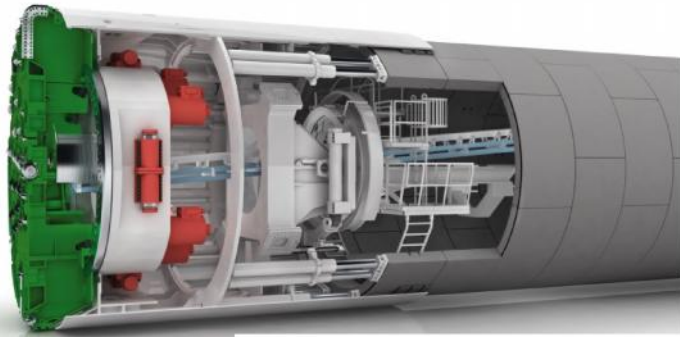

Hard rock:

- Damages indicated by indirect sensors
- Cutter load to limit risk

A. INTRODUCTION

Cutting tools:

- Overview of tools at different cutting wheels:

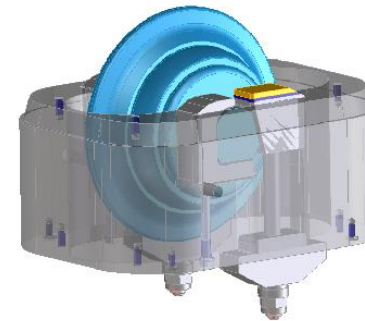
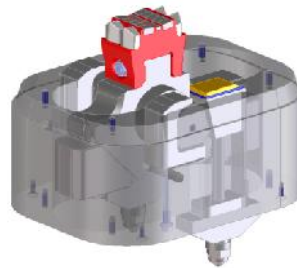
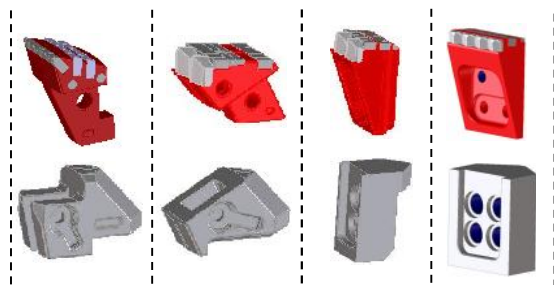

C. Monitoring

What does monitoring mean?					
Wear detection	Cutter discs conditions	Online load measuring		Online wear measuring	Visual inspection
SG tools with wear detection	Hard rock	Load measuring of disc cutters		Softground	Remote controlled robot in SG
Cutter head wear detection.	Softground	Direct	Indirect		Cleaning of cutter head
Indirect Disc cutter wear detection					Inspection of Cutterhead /tools
Looking for wear limits	Indication of tool conditions	Looking for load limits, Geotechnical indications		Avoid compressed air interventions	Informations and reactions

D. MONITORING SYSTEMS

Soft ground tool monitoring

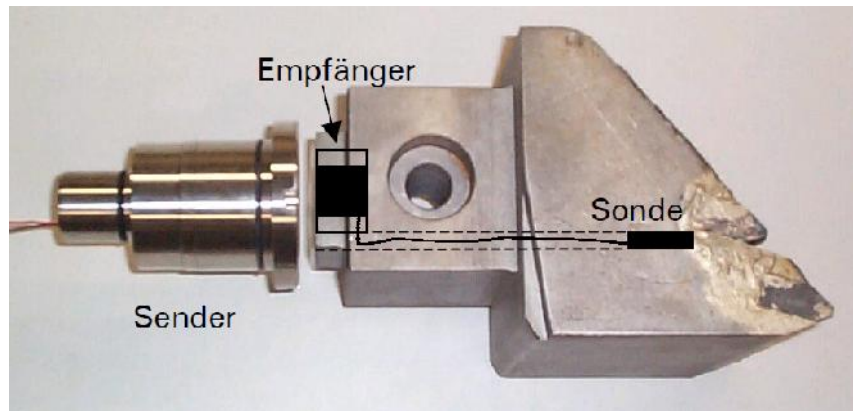

Indication for high wear or damaged tools / cutter head



Ausführung mit Drahtschleifer und Taster

D. MONITORING SYSTEMS

Disc Cutter Rotation Monitoring (DCRM):

- System structure:

Hard rock TBMs

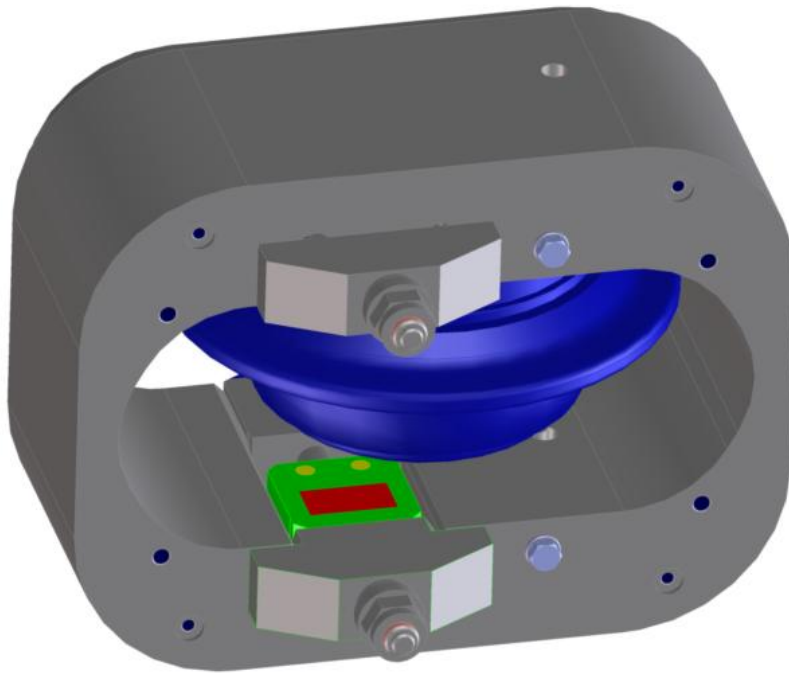

Hydroshield TBM with accessible cutting wheel

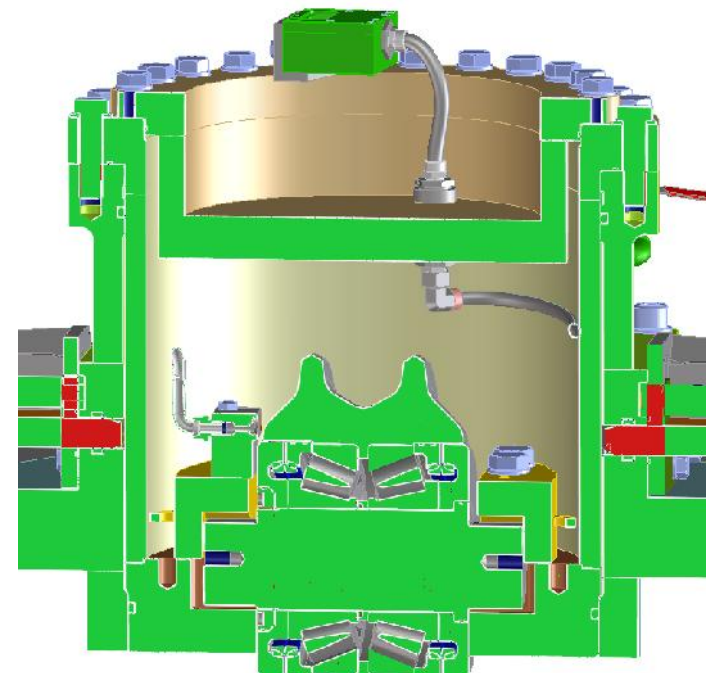

D. MONITORING SYSTEMS

Disc Cutter Rotation Monitoring (DCRM):

- Signal transmission on hard rock machines:

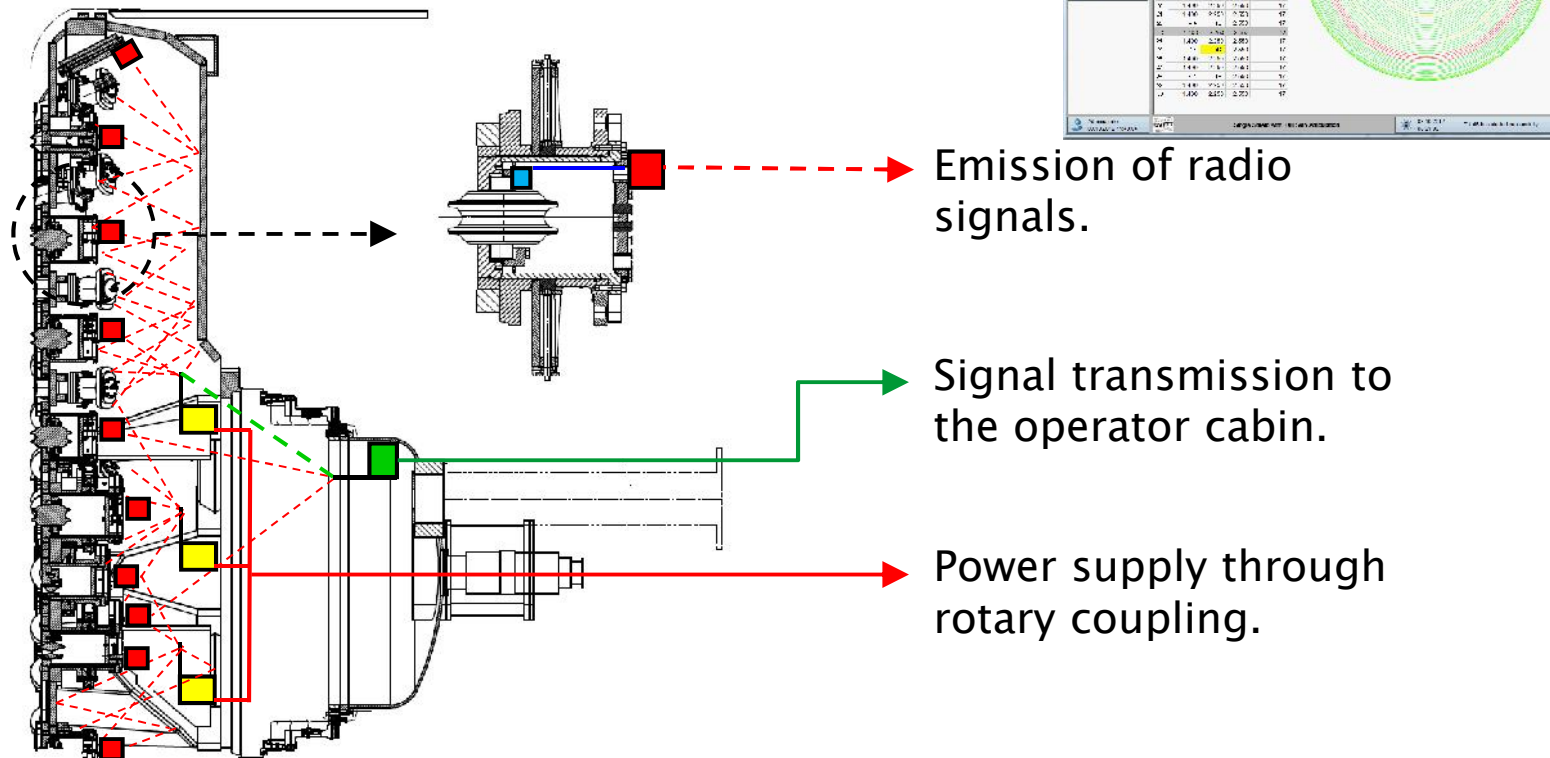

F. CHANGE

Accessible cutter heads:

- Individual tools are equipped with pressure locks for atmospheric change

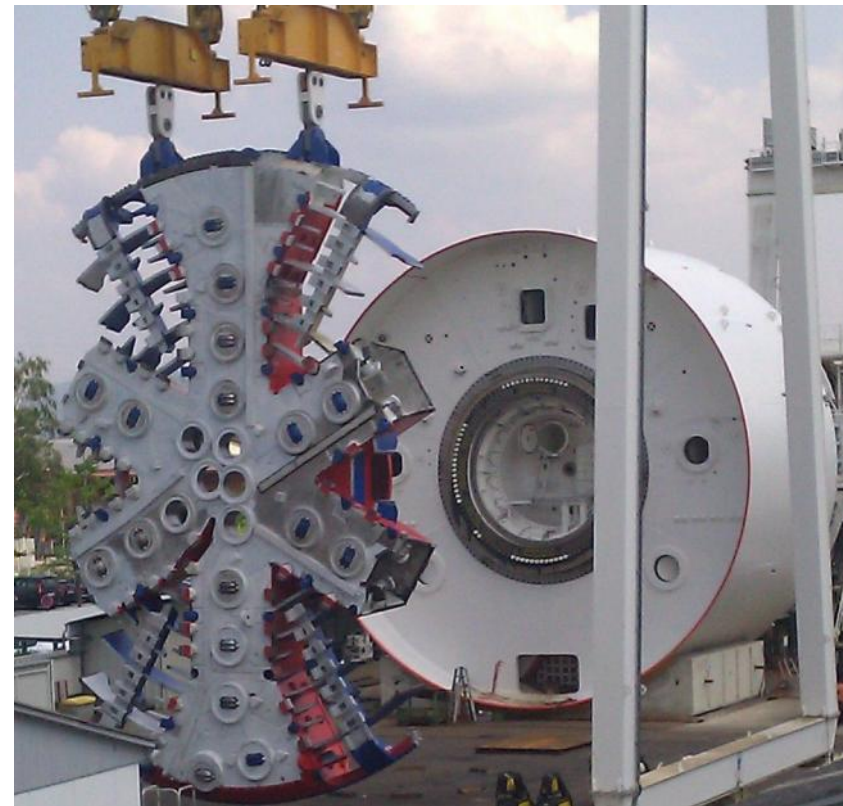

D. MONITORING SYSTEMS

Disc Cutter Load Monitoring (DCLM):

- System structure:

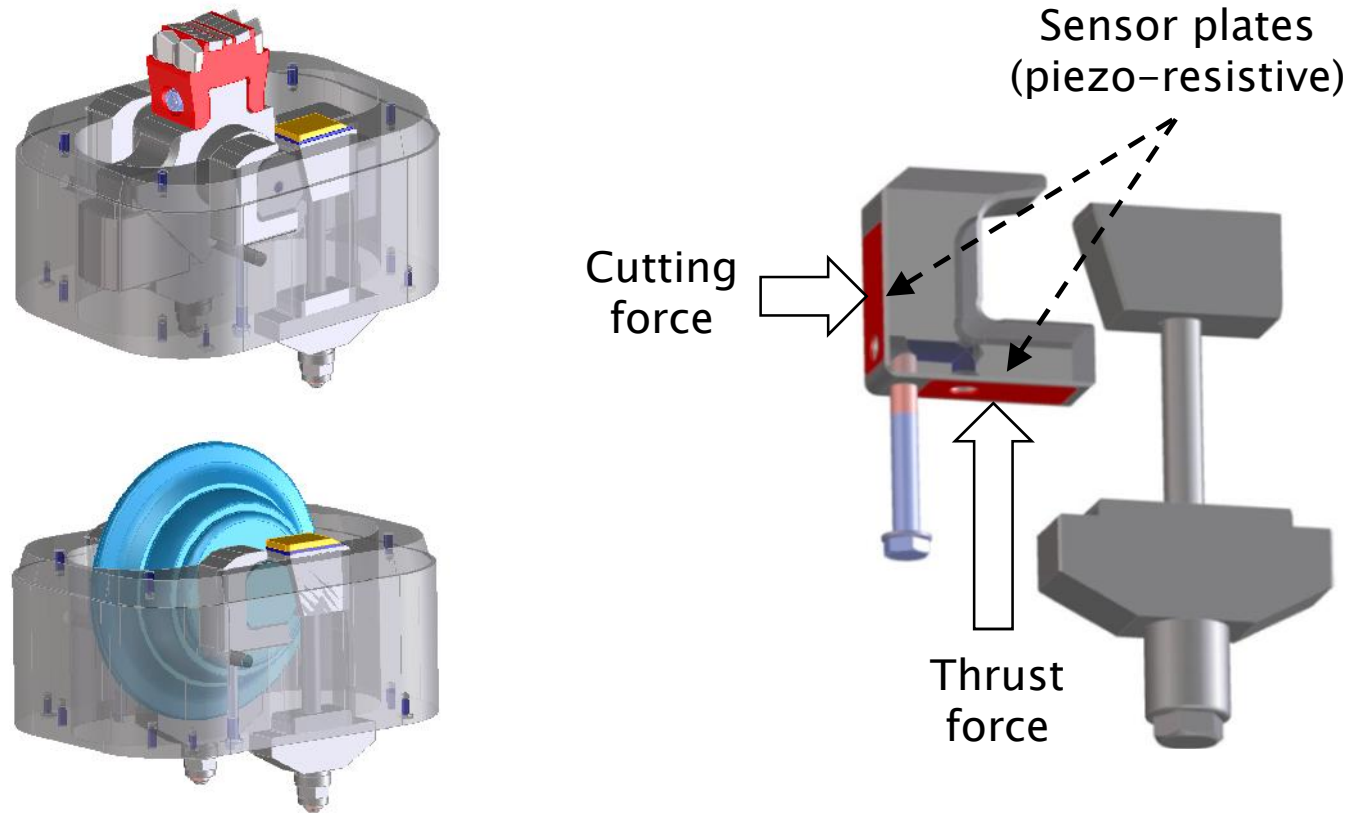

D. MONITORING SYSTEMS

Disc Cutter Wear Monitoring (DCWM):

- System structure for Hydroshield TBM with accessible cutterheads:

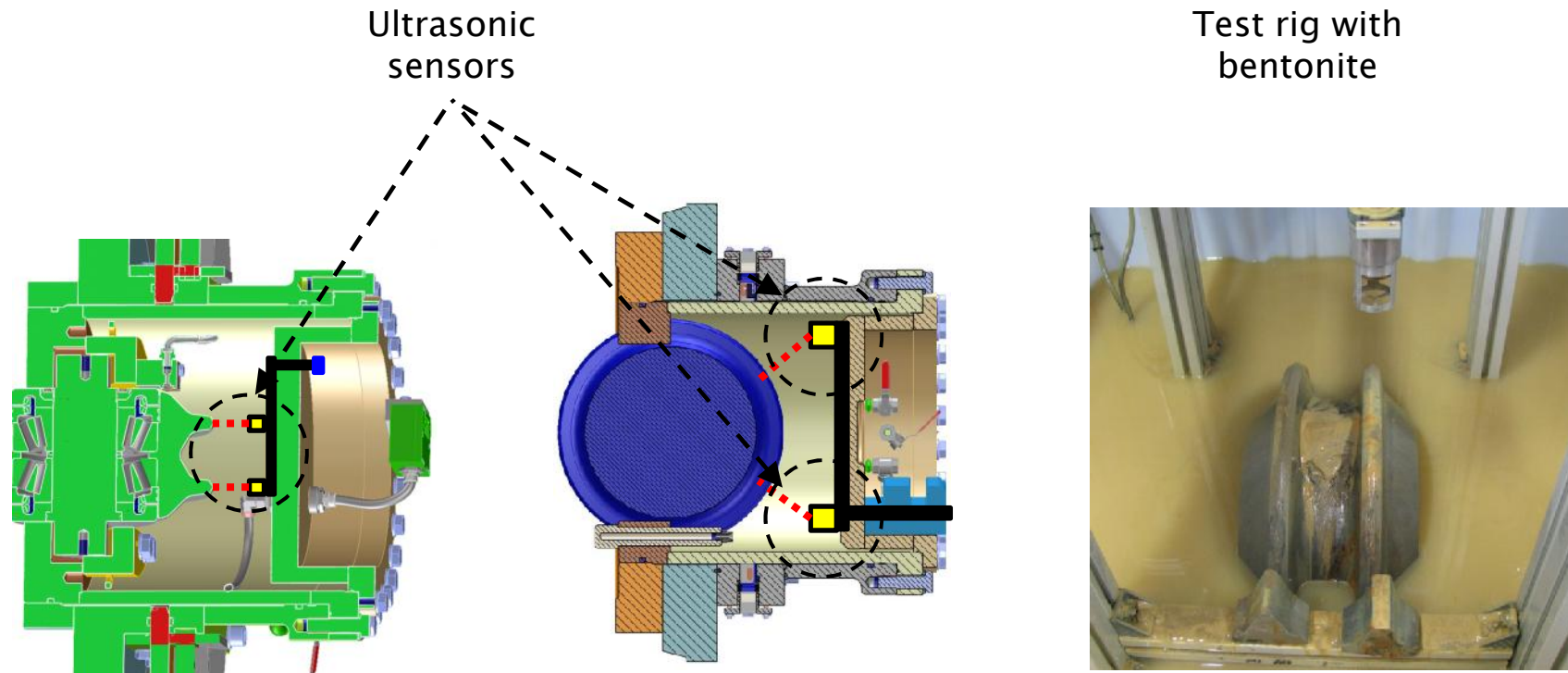

D. MONITORING SYSTEMS

Disc Cutter Wear Monitoring (DCWM):

■ Test system measurement results:

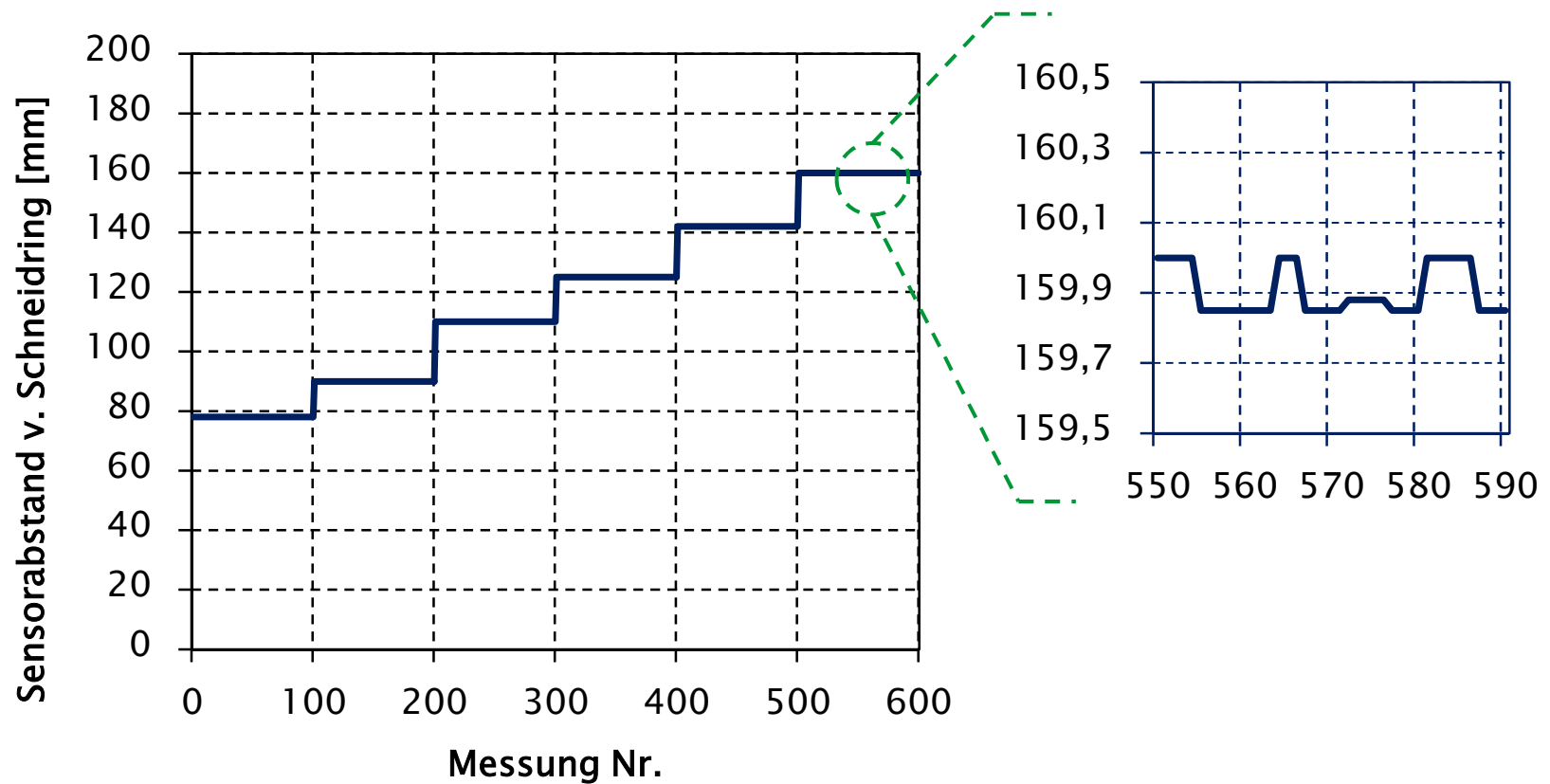

E. INSPECTION

Assisted tool inspection:

- System structure:
 - Extendible inspection robot in tube garage
 - Assembly of the garage between pressure wall and submerged wall
 - Opening towards the excavation chamber

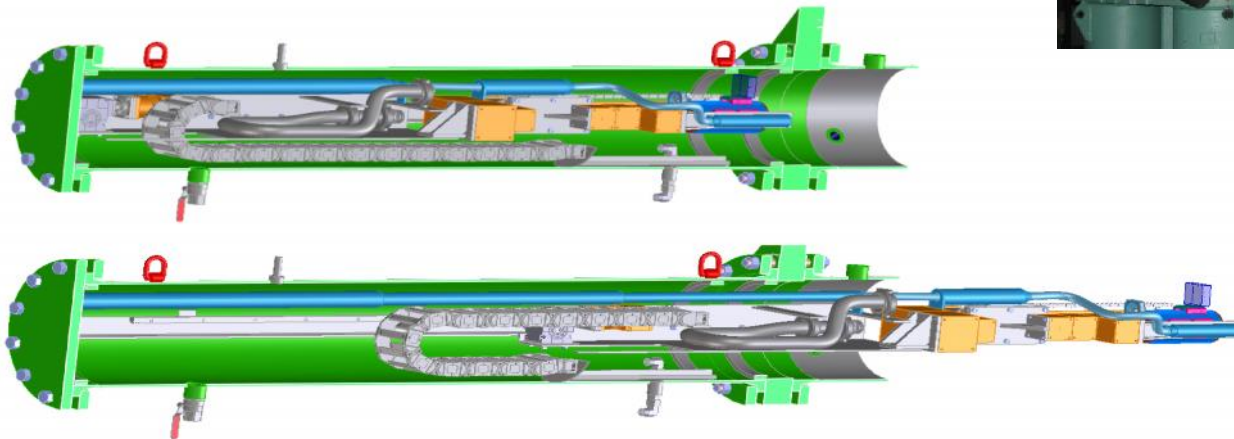

E. INSPECTION

Assisted tool inspection:

- Application on Hydroshield TBM:

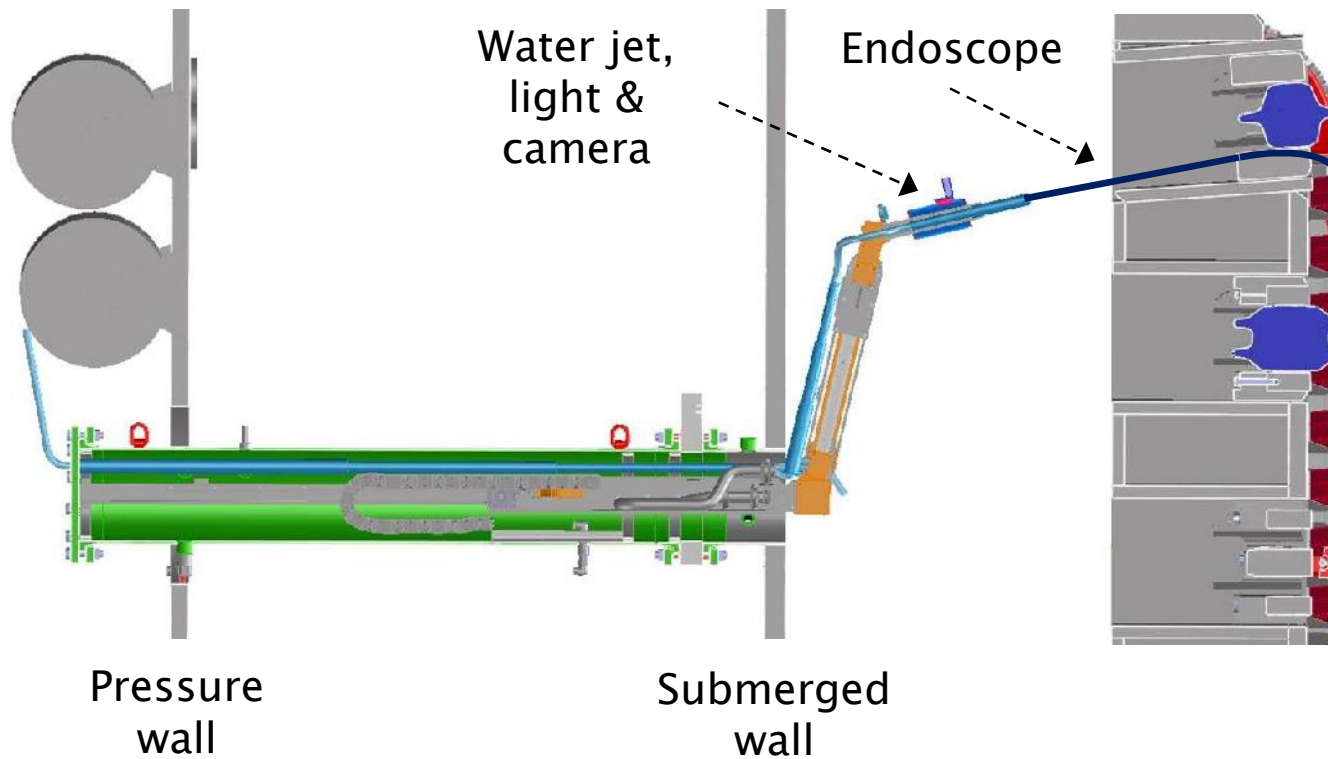

F. CHANGE

Assisted & automated cutting tool change:

- Support structure & manipulator:

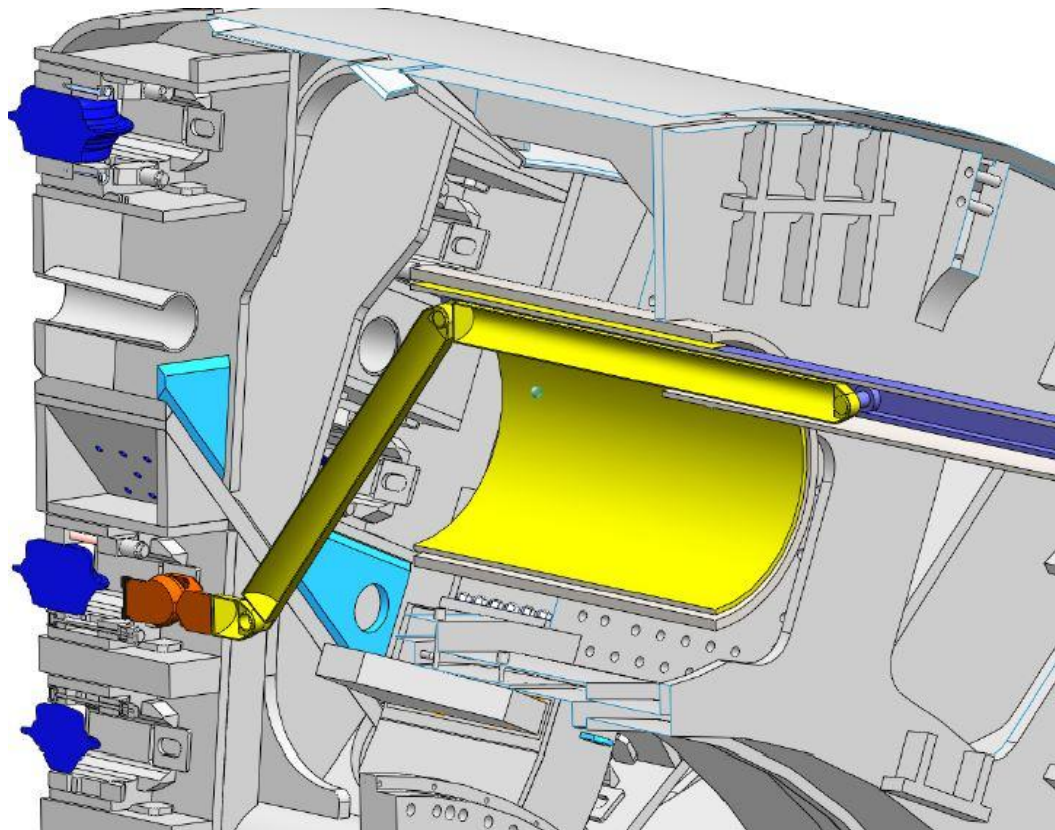

G. SUMMARY

	Hardrock TBM	Hydroshield TBM EPB TBM
Direct / Indirect monitoring	Existing systems	Existing systems
Cutter conditions	DCRM – Hard rock	DCRM – FSP, DCRM – SG under development
Online load measuring	DCLM – Prototyp available (see S. Barwart)	
Online wear measuring	manually	DCWM – Prototyp in validation
Visual inspection	manually	Prototype under development
Tool change:	Assistance system under progress. Status: initial studies. Automated system under progress. Status: initial studies.	



Thank you for your
attention!